

Type : 4EL160L4F-PC-BA-000

Date : 01.01.2023

Power [kW]	: 15.0	Efficiency Class	: IE4
Input Voltage [V]	: 400	Duty Cycle	: S1
Connection Type [Δ / Y]	: Δ	Service Factor	: 1.25
Frequency [Hz]	: 50	Frame Size	: 160L
Pole Number	: 4	Weight [kg]	: 112
Nominal Speed [rpm]	: 1475	Insulation Class	: F [155°C]
Nominal Current [A]	: 28.9	Temperature Rise	: B [80°C]
Nominal Moment [Nm]	: 97.5	Protection Class	: IP55
Nominal Efficiency [η]	: 93.9	Vibration Severity Grade	: A
Power Factor [cosφ]	: 0.80	Method of Cooling	: IC411 (TEFC)
Locked Rotor Current [Ia/In]	: 8.7	Direction of Rotation	: Bidirectional
Locked Rotor Torque [Ma/Mn]	: 3.7	Balance	: Half Key
Breakdown Torque [Mk/Mn]	: 4.3	Motor Thermal Protection	: PTC
Motor Color	: RAL 7031	Altitude Above Sea Level	: 1000m
Ambient Temperature	: -15°C / +40°C	Sound Pressure Level [dBA]	: 64

ELECTRICAL DATA

Δ / Y	U [V]	f [Hz]	P [kW]	n [rpm]	I [A]	η [%100]	η [%75]	η [%50]	Cosφ	Cl
Δ	400	50	15.0	1475	28.9	93.9	94.1	93.8	0.80	IE4
Y	690	50	15.0	1475	16.7	93.9	94.1	93.8	0.80	IE4
Δ	460	60	15.0	1775	25.3	94.1	94.0	93.2	0.79	IE4
Δ	460	60	17.4	1770	28.5	94.5	94.6	94.3	0.81	IE4

MECHANICAL DATA

Moment of Inertia [kgm ²]	: 0.12000
Bearing [DS / NS]	: 6309ZZ / 6209ZZ
Frame Material	: Aluminum
Flange Type / Material	: B14 / Cast Iron
Cooling Fan Material	: Plastic
End Shield Material	: Aluminum

TERMINAL BOX

Terminal Box Material	: Aluminum
Terminal Box Position	: Top
Terminal Box Cable Entry	: 2xM32x1.5
Terminal Box Blind Cap	: --
Contact Screw Thread	: M6

MECHANICAL DIMENSIONS

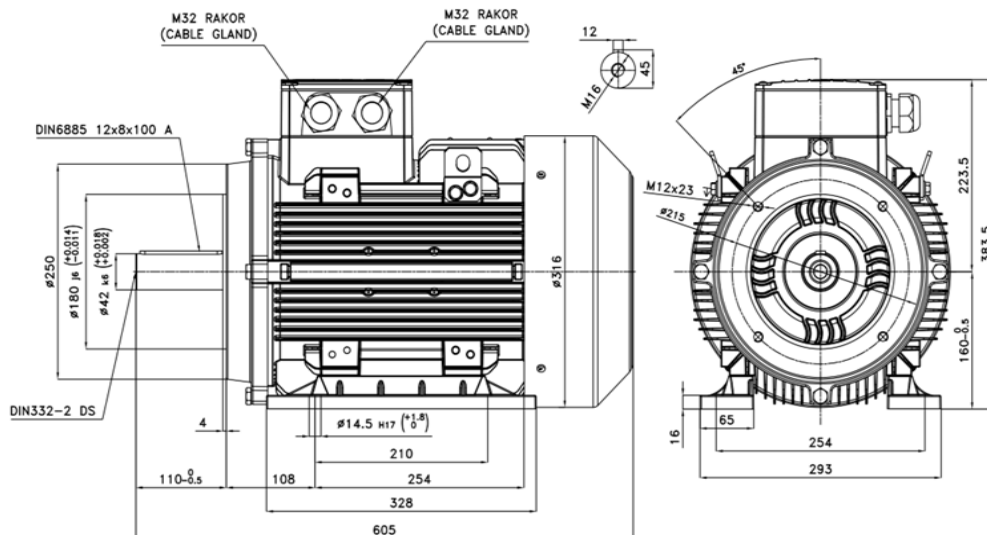

Manufactured and tested in accordance with IEC 60034

*Technical data are subject to change! There may be discrepancies between calculated and rating plate values.

*ELK Motor has right to change all the data without prior notice.

FR.AG.010 REV.NO: 04 REV.DATE: 01.01.2023



ELK MOTOR SAN. ve TİC. A.Ş.
www.elkmotor.com.tr
+90 (282) 726 92 94

TECHNICAL DATASHEET ACCORDING TO COMMISSION REGULATION (EU) 2019/1781 THREE PHASE INDUCTION MOTOR - SQUIRREL CAGE

Type : 4EL160L4F-PC-BA-000

Date : 01.01.2023

NAMEPLATE DATA

Power [kW]	: 15.0	Nominal Speed [rpm]	: 1475
Nominal Voltage [V]	: 400	Nominal Current [A]	: 28.9
Connection Type [Δ / Y]	: Δ	Nominal Moment [Nm]	: 97.5
Nominal Frequency [Hz]	: 50	Nominal Efficiency [η %]	: 93.9

THE POWER LOSSES AT SEVEN OPERATING POINTS ACCORDING TO COMMISSION REGULATION (EU) 2019/1781

Operating Point Number	Speed n/n_N [%]	Torque T/T_N [%]	Relative Power Losses P_L/P_N [%]	Efficiency η [%]
P ₁	90	100	6.8	93.0
P ₂	50	100	5.0	90.9
P ₃	25	100	4.4	85.1
P ₄	90	50	4.5	90.8
P ₅	50	50	2.6	90.5
P ₆	50	25	2.0	86.0
P ₇	25	25	1.2	84.0

MAP OF RELATIVE POWER LOSSES P_L/P_N [%]

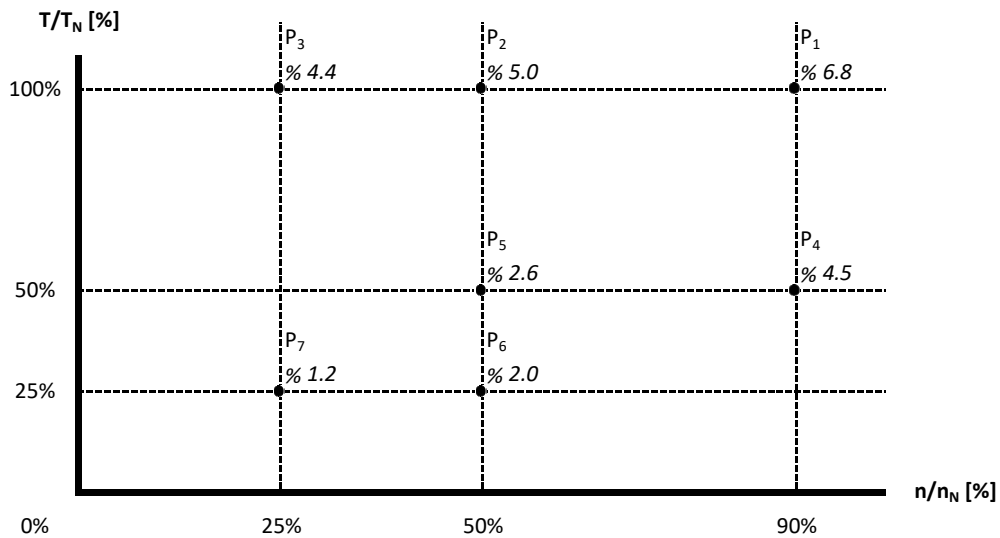

Manufactured and tested in accordance with IEC 60034

FR.AG.010 REV.NO: 04 REV.DATE: 01.01.2023

*Technical data are subject to change! There may be discrepancies between calculated and rating plate values.

*ELK Motor has right to change all the data without prior notice.

Motor Code : 4EL160L4F-PC-BA-000

Torque and Current Curves Related to Speed

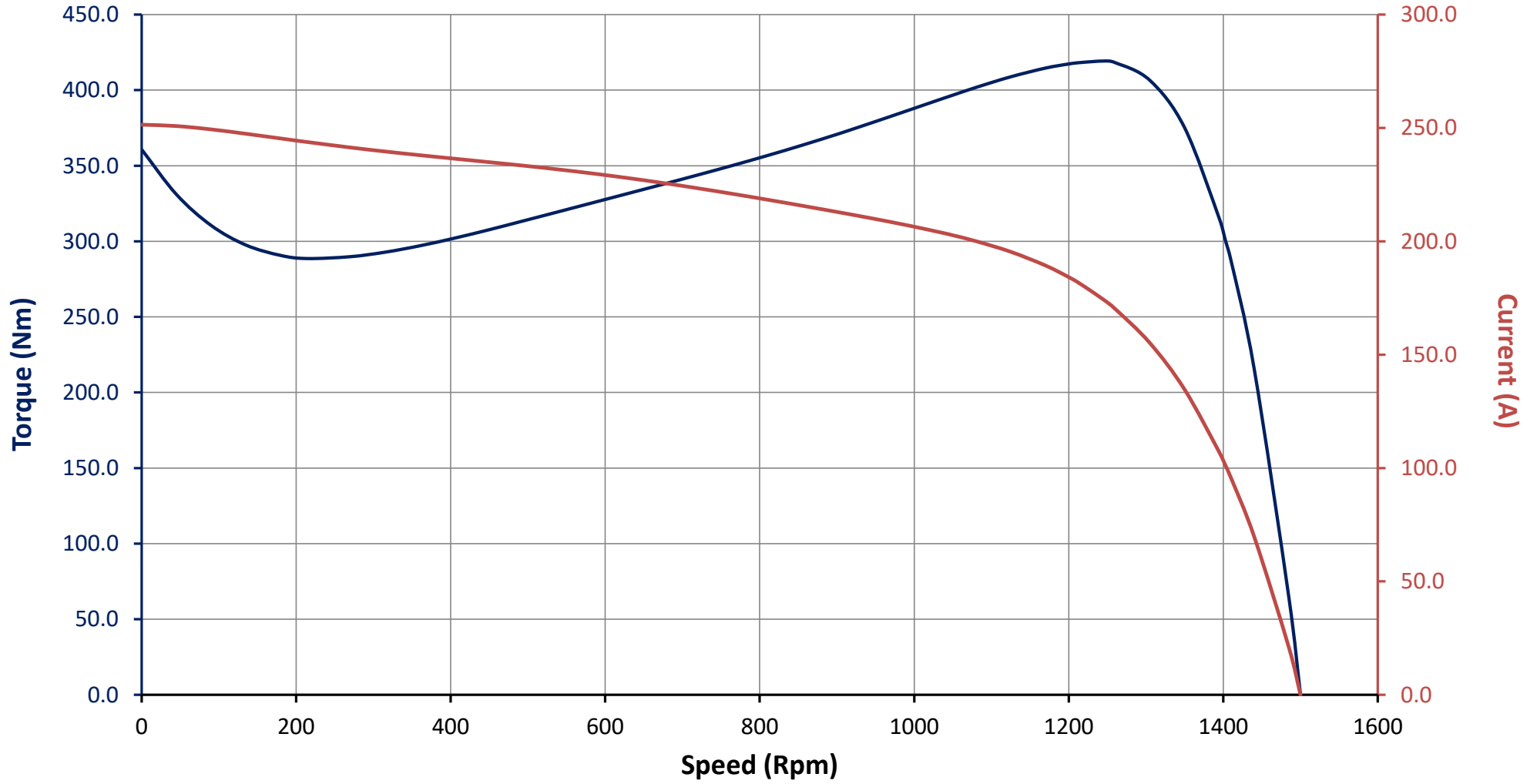

Motor Code : 4EL160L4F-PC-BA-000

Performance Curves Related to Rated Output

