

Type : 3EG280M6C-FA-BA-000

Date : 01.01.2023

Power [kW]	: 55.0	Efficiency Class	: IE3
Input Voltage [V]	: 400	Duty Cycle	: S1
Connection Type [Δ / Y]	: Δ	Service Factor	: 1.20
Frequency [Hz]	: 50	Frame Size	: 280M
Pole Number	: 6	Weight [kg]	: 620
Nominal Speed [rpm]	: 989	Insulation Class	: F [155°C]
Nominal Current [A]	: 102	Temperature Rise	: B [80°K]
Nominal Moment [Nm]	: 531	Protection Class	: IP55
Nominal Efficiency [η]	: 94.1	Vibration Severity Grade	: A
Power Factor [$\cos\phi$]	: 0.83	Method of Cooling	: IC411 (TEFC)
Locked Rotor Current [I_a/I_n]	: 6.9	Direction of Rotation	: Bidirectional
Locked Rotor Torque [M_a/M_n]	: 2.9	Balance	: Half Key
Breakdown Torque [M_k/M_n]	: 2.8	Motor Thermal Protection	: PTC
Motor Color	: RAL 7031	Altitude Above Sea Level	: 1000m
Ambient Temperature	: -15°C / +40°C	Sound Pressure Level [dBA]	: 65

ELECTRICAL DATA

Δ / Y	U [V]	f [Hz]	P [kW]	n [rpm]	I [A]	η [%100]	η [%75]	η [%50]	Cos ϕ	Cl
Δ	400	50	55.0	989	102	94.1	94.4	93.5	0.83	IE3
Y	690	50	55.0	989	58.9	94.1	94.4	93.5	0.83	IE3

MECHANICAL DATA

Moment of Inertia [kgm ²]	: 1.65000
Bearing [DS / NS]	: 6317 / 6317
Frame Material	: Cast Iron
Flange Type / Material	: B5 / Cast Iron
Cooling Fan Material	: Plastic
End Shield Material	: Cast Iron
Lubrication of Bearings [DS / NS]	: 9000h-38gr / 11000h-38gr MOBIL Polyrex EM

TERMINAL BOX

Terminal Box Material	: Cast Iron
Terminal Box Position	: Top
Terminal Box Cable Entry	: 2xM63x1.5
Terminal Box Blind Cap	: --
Contact Screw Thread	: M10

MECHANICAL DIMENSIONS

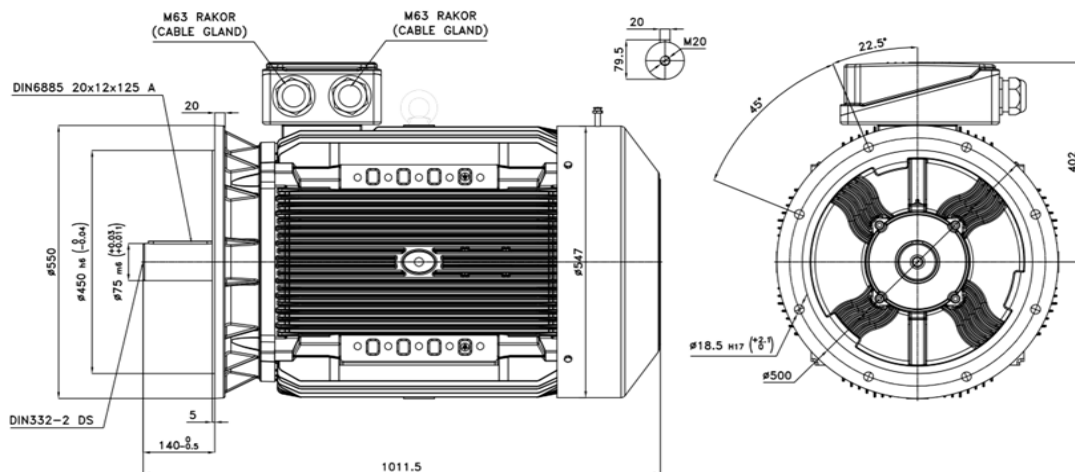

Manufactured and tested in accordance with IEC 60034

*Technical data are subject to change! There may be discrepancies between calculated and rating plate values.

*ELK Motor has right to change all the data without prior notice.

FR.AG.010 REV.NO: 04 REV.DATE: 01.01.2023



ELK MOTOR SAN. ve TİC. A.Ş.
www.elkmotor.com.tr
+90 (282) 726 92 94

TECHNICAL DATASHEET ACCORDING TO COMMISSION REGULATION (EU) 2019/1781 THREE PHASE INDUCTION MOTOR - SQUIRREL CAGE

Type : 3EG280M6C-FA-BA-000

Date : 01.01.2023

NAMEPLATE DATA

Power [kW]	: 55.0	Nominal Speed [rpm]	: 989
Nominal Voltage [V]	: 400	Nominal Current [A]	: 102
Connection Type [Δ / Y]	: Δ	Nominal Moment [Nm]	: 531
Nominal Frequency [Hz]	: 50	Nominal Efficiency [η %]	: 94.1

THE POWER LOSSES AT SEVEN OPERATING POINTS ACCORDING TO COMMISSION REGULATION (EU) 2019/1781

Operating Point Number	Speed n/n_N [%]	Torque T/T_N [%]	Relative Power Losses P_L/P_N [%]	Efficiency η [%]
P ₁	90	100	6.6	93.2
P ₂	50	100	4.7	91.4
P ₃	25	100	4.0	86.4
P ₄	90	50	4.3	91.4
P ₅	50	50	2.4	91.2
P ₆	50	25	1.8	87.4
P ₇	25	25	1.0	85.8

MAP OF RELATIVE POWER LOSSES P_L/P_N [%]

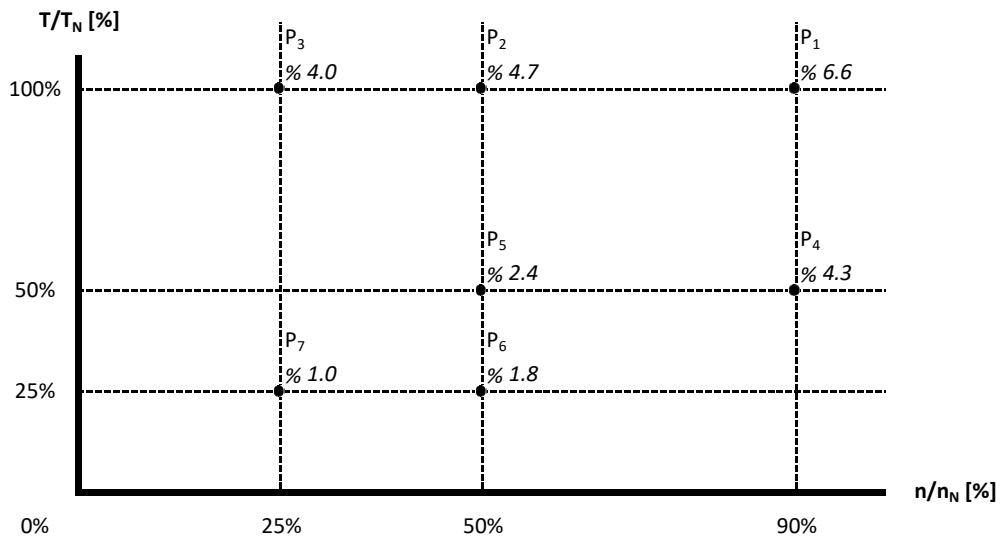

Manufactured and tested in accordance with IEC 60034

FR.AG.010 REV.NO: 04 REV.DATE: 01.01.2023

*Technical data are subject to change! There may be discrepancies between calculated and rating plate values.

*ELK Motor has right to change all the data without prior notice.

Motor Code : 3EG280M6C-FA-BA-000

Torque and Current Curves Related to Speed

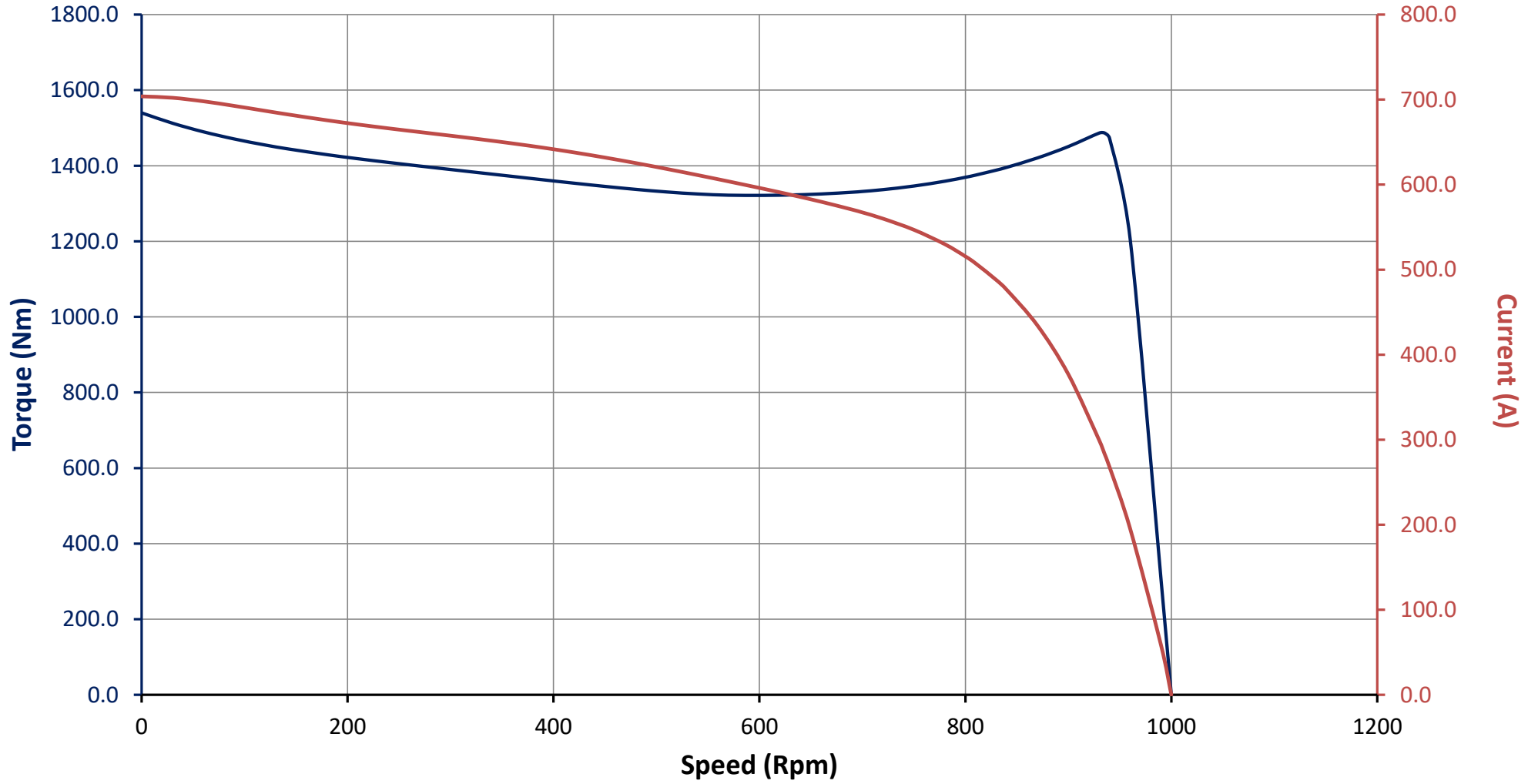

Motor Code : 3EG280M6C-FA-BA-000

Performance Curves Related to Rated Output

