

Type : 2EL063M4B-FC-A0-000**Date** : 01.01.2023

Power [kW]	: 0.12	Efficiency Class	: IE2
Input Voltage [V]	: 400	Duty Cycle	: S1
Connection Type [Δ / Y]	: Y	Service Factor	: 1.15
Frequency [Hz]	: 50	Frame Size	: 063M
Pole Number	: 4	Weight [kg]	: 4.00
Nominal Speed [rpm]	: 1400	Insulation Class	: F [155°C]
Nominal Current [A]	: 0.42	Temperature Rise	: B [80°K]
Nominal Moment [Nm]	: 0.82	Protection Class	: IP55
Nominal Efficiency [η]	: 60.1	Vibration Severity Grade	: A
Power Factor [cosφ]	: 0.70	Method of Cooling	: IC411 (TEFC)
Locked Rotor Current [Ia/In]	: 3.0	Direction of Rotation	: Bidirectional
Locked Rotor Torque [Ma/Mn]	: 2.1	Balance	: Half Key
Breakdown Torque [Mk/Mn]	: 2.3	Motor Thermal Protection	: --
Motor Color	: RAL 7031	Altitude Above Sea Level	: 1000m
Ambient Temperature	: -15°C / +40°C	Sound Pressure Level [dBA]	: 42

ELECTRICAL DATA

Δ / Y	U [V]	f [Hz]	P [kW]	n [rpm]	I [A]	η [%100]	η [%75]	η [%50]	Cosφ	Cl
Δ	230	50	0.12	1400	0.73	60.1	60.5	54.5	0.70	IE2
Y	400	50	0.12	1400	0.42	60.1	60.5	54.5	0.70	IE2
Y	460	60	0.12	1710	0.37	64.0	64.2	58.1	0.64	IE2
Y	460	60	0.14	1700	0.40	64.0	64.4	58.4	0.70	IE2

MECHANICAL DATA

Moment of Inertia [kgm ²]	: 0.00018
Bearing [DS / NS]	: 6201ZZ / 6201ZZ
Frame Material	: Aluminum
Flange Type / Material	: B14 / Aluminum
Cooling Fan Material	: Plastic
End Shield Material	: Aluminum

TERMINAL BOX

Terminal Box Material	: Aluminum
Terminal Box Position	: Top
Terminal Box Cable Entry	: M16x1.5
Terminal Box Blind Cap	: M16x1.5
Contact Screw Thread	: M4

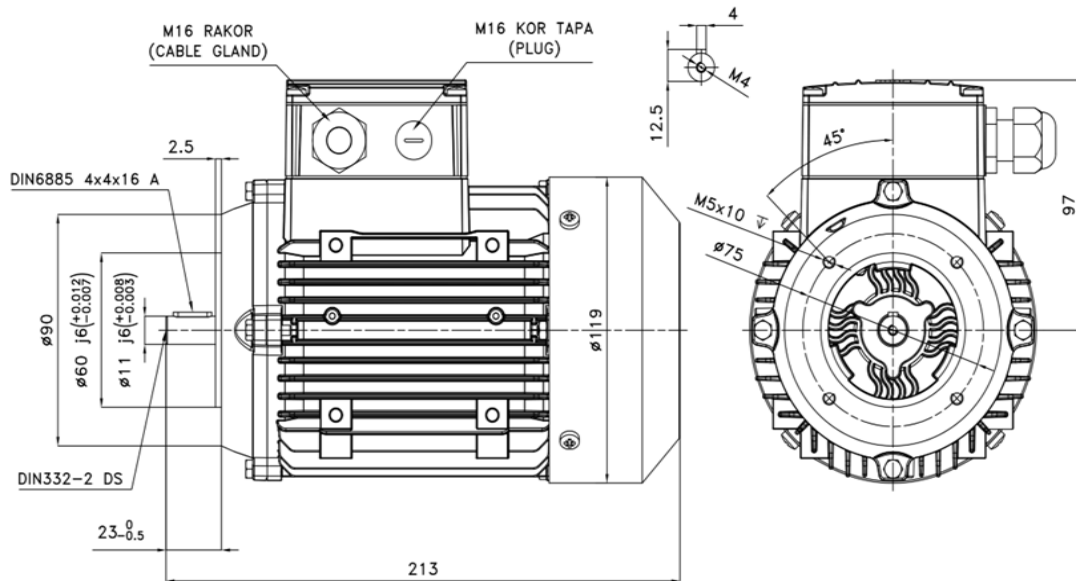
MECHANICAL DIMENSIONS

Manufactured and tested in accordance with IEC 60034

*Technical data are subject to change! There may be discrepancies between calculated and rating plate values.

*ELK Motor has right to change all the data without prior notice.

FR.AG.010 REV.NO: 04 REV.DATE: 01.01.2023



ELK MOTOR SAN. ve TİC. A.Ş.
www.elkmotor.com.tr
+90 (282) 726 92 94

TECHNICAL DATASHEET ACCORDING TO COMMISSION REGULATION (EU) 2019/1781 THREE PHASE INDUCTION MOTOR - SQUIRREL CAGE

Type : 2EL063M4B-FC-A0-000

Date : 01.01.2023

NAMEPLATE DATA

Power [kW]	: 0.12	Nominal Speed [rpm]	: 1400
Nominal Voltage [V]	: 400	Nominal Current [A]	: 0.42
Connection Type [Δ / Y]	: Y	Nominal Moment [Nm]	: 0.82
Nominal Frequency [Hz]	: 50	Nominal Efficiency [η %]	: 60.1

THE POWER LOSSES AT SEVEN OPERATING POINTS ACCORDING TO COMMISSION REGULATION (EU) 2019/1781

Operating Point Number	Speed n/n_N [%]	Torque T/T_N [%]	Relative Power Losses P_L/P_N [%]	Efficiency η [%]
P ₁	90	100	59.8	60.1
P ₂	50	100	56.0	47.2
P ₃	25	100	54.2	31.6
P ₄	90	50	49.3	47.7
P ₅	50	50	30.7	44.8
P ₆	50	25	30.3	29.2
P ₇	25	25	17.4	27.7

MAP OF RELATIVE POWER LOSSES P_L/P_N [%]

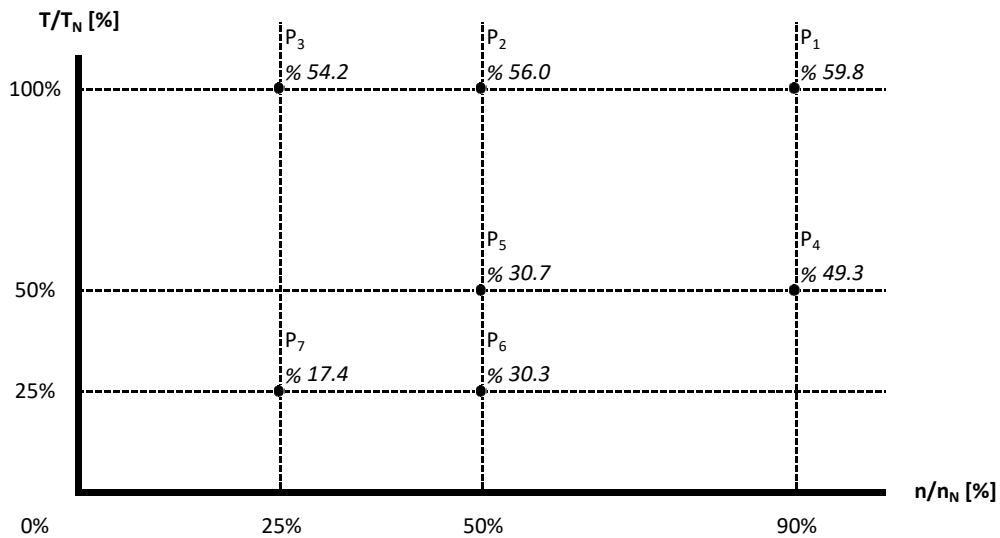

Manufactured and tested in accordance with IEC 60034

FR.AG.010 REV.NO: 04 REV.DATE: 01.01.2023

*Technical data are subject to change! There may be discrepancies between calculated and rating plate values.

*ELK Motor has right to change all the data without prior notice.

Motor Code : 2EL063M4B-FC-A0-000

Torque and Current Curves Related to Speed

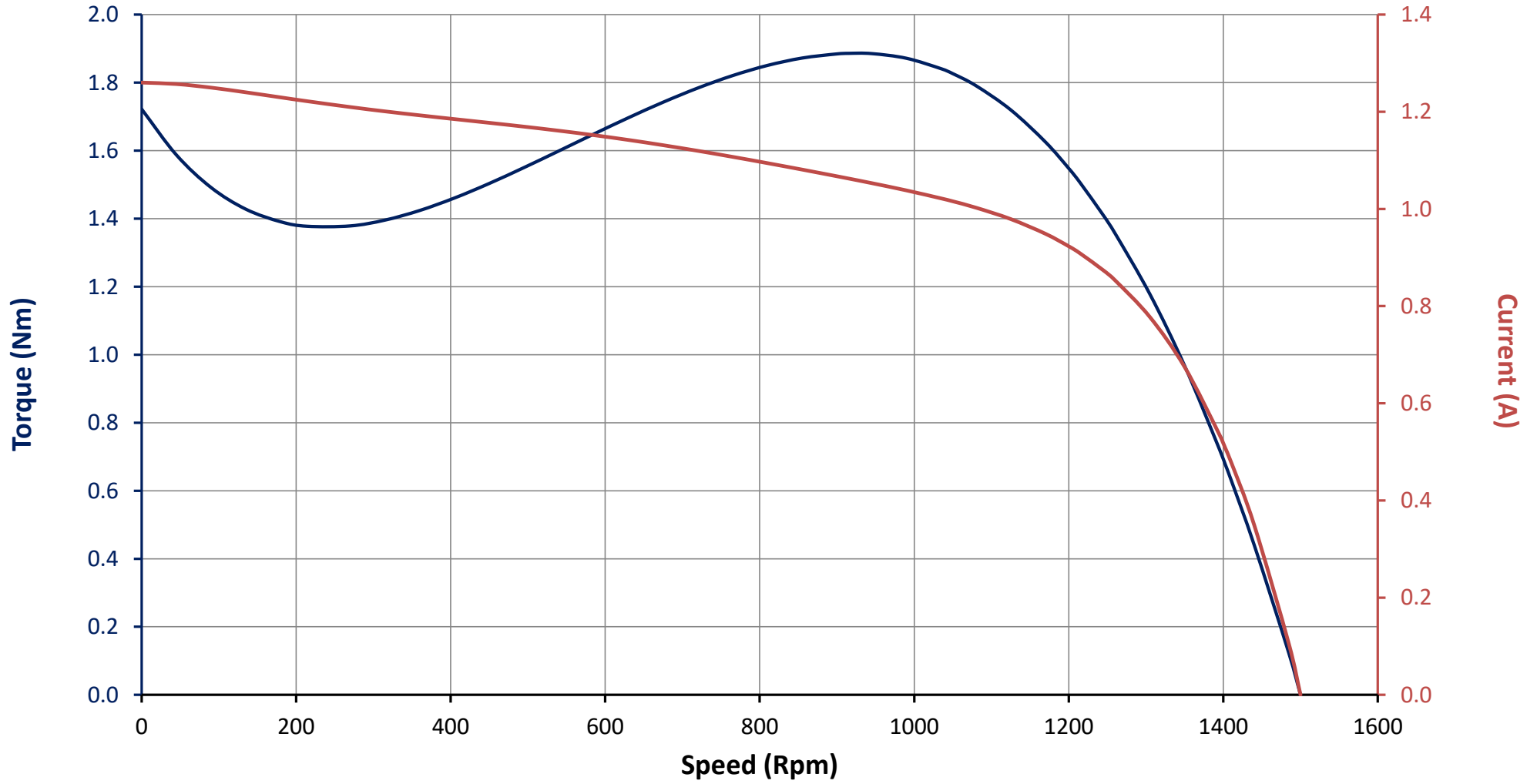

Motor Code : 2EL063M4B-FC-A0-000

Performance Curves Related to Rated Output

