

Type : 4EL112M2D-FA-B0-000

Date : 01.01.2023

Power [kW]	: 4.00	Efficiency Class	: IE4
Input Voltage [V]	: 400	Duty Cycle	: S1
Connection Type [Δ / Y]	: Δ	Service Factor	: 1.25
Frequency [Hz]	: 50	Frame Size	: 112M
Pole Number	: 2	Weight [kg]	: 32.2
Nominal Speed [rpm]	: 2940	Insulation Class	: F [155°C]
Nominal Current [A]	: 7.30	Temperature Rise	: B [80°C]
Nominal Moment [Nm]	: 13.0	Protection Class	: IP55
Nominal Efficiency [η]	: 90.0	Vibration Severity Grade	: A
Power Factor [cosφ]	: 0.88	Method of Cooling	: IC411 (TEFC)
Locked Rotor Current [Ia/In]	: 8.7	Direction of Rotation	: Bidirectional
Locked Rotor Torque [Ma/Mn]	: 3.0	Balance	: Half Key
Breakdown Torque [Mk/Mn]	: 4.2	Motor Thermal Protection	: --
Motor Color	: RAL 7031	Altitude Above Sea Level	: 1000m
Ambient Temperature	: -15°C / +40°C	Sound Pressure Level [dBA]	: 70

ELECTRICAL DATA

Δ / Y	U [V]	f [Hz]	P [kW]	n [rpm]	I [A]	η [%100]	η [%75]	η [%50]	Cosφ	Cl
Δ	400	50	4.00	2940	7.30	90.0	90.3	89.7	0.88	IE4
Y	690	50	4.00	2940	4.21	90.0	90.3	89.7	0.88	IE4
Δ	460	60	4.00	3540	6.43	89.7	89.0	87.1	0.87	IE4
Δ	460	60	4.55	3530	7.21	89.7	89.9	89.3	0.89	IE4

MECHANICAL DATA

Moment of Inertia [kgm ²]	: 0.00734
Bearing [DS / NS]	: 6206ZZ / 6206ZZ
Frame Material	: Aluminum
Flange Type / Material	: B5 / Aluminum
Cooling Fan Material	: Plastic
End Shield Material	: Aluminum

TERMINAL BOX

Terminal Box Material	: Aluminum
Terminal Box Position	: Top
Terminal Box Cable Entry	: M25x1.5
Terminal Box Blind Cap	: M25x1.5
Contact Screw Thread	: M5

MECHANICAL DIMENSIONS

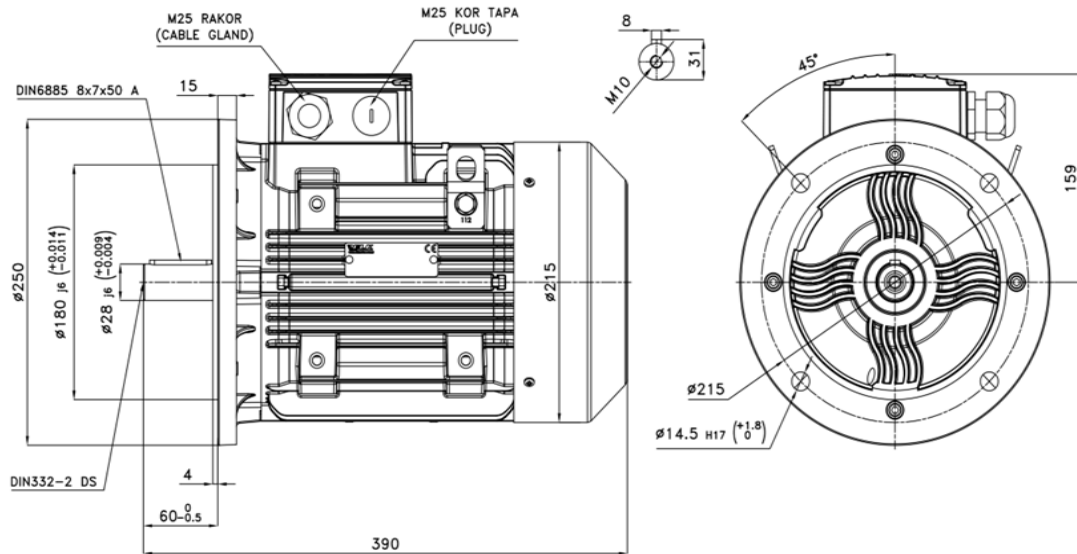

Manufactured and tested in accordance with IEC 60034

*Technical data are subject to change! There may be discrepancies between calculated and rating plate values.

*ELK Motor has right to change all the data without prior notice.

FR.AG.010 REV.NO: 04 REV.DATE: 01.01.2023



ELK MOTOR SAN. ve TİC. A.Ş.
www.elkmotor.com.tr
+90 (282) 726 92 94

TECHNICAL DATASHEET ACCORDING TO COMMISSION REGULATION (EU) 2019/1781 THREE PHASE INDUCTION MOTOR - SQUIRREL CAGE

Type : 4EL112M2D-FA-B0-000

Date : 01.01.2023

NAMEPLATE DATA

Power [kW]	: 4.00	Nominal Speed [rpm]	: 2940
Nominal Voltage [V]	: 400	Nominal Current [A]	: 7.30
Connection Type [Δ / Y]	: Δ	Nominal Moment [Nm]	: 13.0
Nominal Frequency [Hz]	: 50	Nominal Efficiency [η %]	: 90.0

THE POWER LOSSES AT SEVEN OPERATING POINTS ACCORDING TO COMMISSION REGULATION (EU) 2019/1781

Operating Point Number	Speed n/n_N [%]	Torque T/T_N [%]	Relative Power Losses P_L/P_N [%]	Efficiency η [%]
P ₁	90	100	10.1	89.9
P ₂	50	100	8.1	86.1
P ₃	25	100	8.7	74.3
P ₄	90	50	6.3	87.8
P ₅	50	50	3.7	87.0
P ₆	50	25	2.7	82.1
P ₇	25	25	1.6	79.2

MAP OF RELATIVE POWER LOSSES P_L/P_N [%]

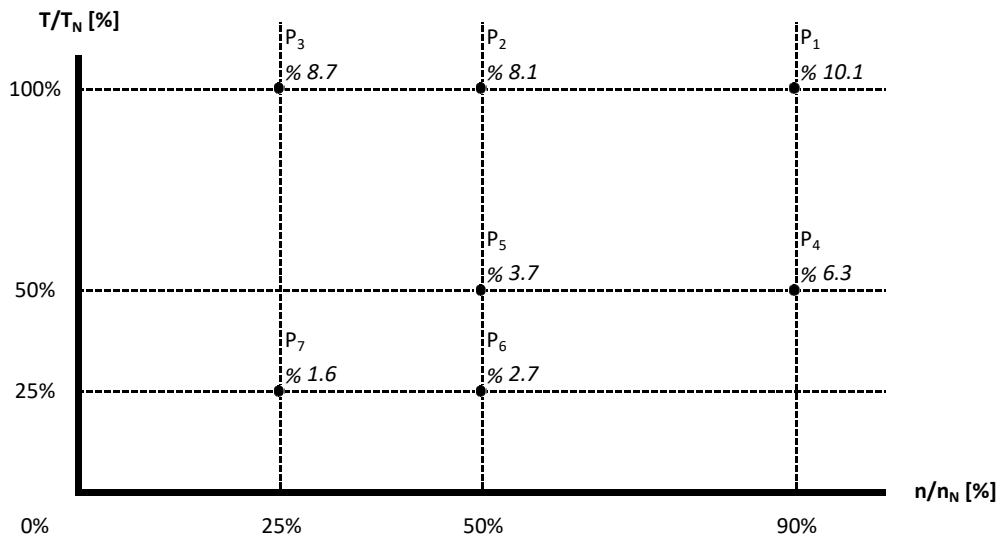

Manufactured and tested in accordance with IEC 60034

FR.AG.010 REV.NO: 04 REV.DATE: 01.01.2023

*Technical data are subject to change! There may be discrepancies between calculated and rating plate values.

*ELK Motor has right to change all the data without prior notice.

Motor Code : 4EL112M2D-FA-B0-000

Torque and Current Curves Related to Speed

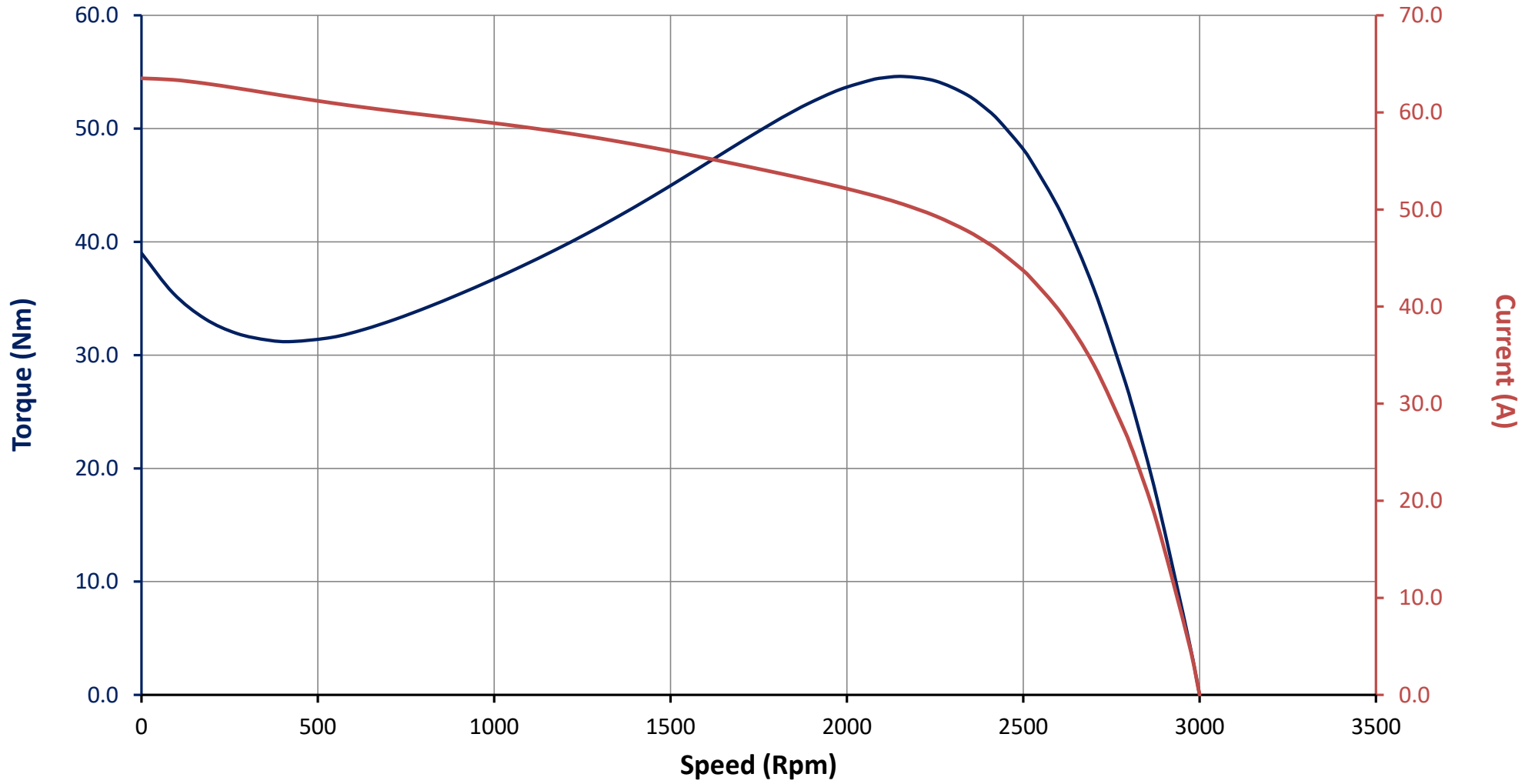

Motor Code : 4EL112M2D-FA-B0-000

Performance Curves Related to Rated Output

