

Type : 4EG280S2C-PA-BA-000

Date : 01.01.2023

Power [kW]	: 75.0	Efficiency Class	: IE4
Input Voltage [V]	: 400	Duty Cycle	: S1
Connection Type [Δ / Y]	: Δ	Service Factor	: 1.25
Frequency [Hz]	: 50	Frame Size	: 280S
Pole Number	: 2	Weight [kg]	: 620
Nominal Speed [rpm]	: 2982	Insulation Class	: F [155°C]
Nominal Current [A]	: 124	Temperature Rise	: B [80°C]
Nominal Moment [Nm]	: 240	Protection Class	: IP55
Nominal Efficiency [η]	: 95.6	Vibration Severity Grade	: A
Power Factor [cosφ]	: 0.91	Method of Cooling	: IC411 (TEFC)
Locked Rotor Current [Ia/In]	: 7.7	Direction of Rotation	: Bidirectional
Locked Rotor Torque [Ma/Mn]	: 2.7	Balance	: Half Key
Breakdown Torque [Mk/Mn]	: 3.2	Motor Thermal Protection	: PTC
Motor Color	: RAL 7031	Altitude Above Sea Level	: 1000m
Ambient Temperature	: -15°C / +40°C	Sound Pressure Level [dBA]	: 76

ELECTRICAL DATA

Δ / Y	U [V]	f [Hz]	P [kW]	n [rpm]	I [A]	η [%100]	η [%75]	η [%50]	Cosφ	Cl
Δ	400	50	75.0	2982	124	95.6	95.6	95.2	0.91	IE4
Y	690	50	75.0	2982	71.8	95.6	95.6	95.2	0.91	IE4
Δ	460	60	75.0	3572	109	95.0	94.6	93.3	0.91	IE4
Δ	460	60	87.0	3570	124	95.4	95.4	95.0	0.92	IE4

MECHANICAL DATA

Moment of Inertia [kgm ²]	: 0.98000
Bearing [DS / NS]	: 6315 / 6315
Frame Material	: Cast Iron
Flange Type / Material	: B5 / Cast Iron
Cooling Fan Material	: Plastic
End Shield Material	: Cast Iron
Lubrication of Bearings [DS / NS]	: 3200h-30gr / 3200h-30gr MOBIL Polyrex EM

TERMINAL BOX

Terminal Box Material	: Cast Iron
Terminal Box Position	: Top
Terminal Box Cable Entry	: 2xM63x1.5
Terminal Box Blind Cap	: --
Contact Screw Thread	: M10

MECHANICAL DIMENSIONS

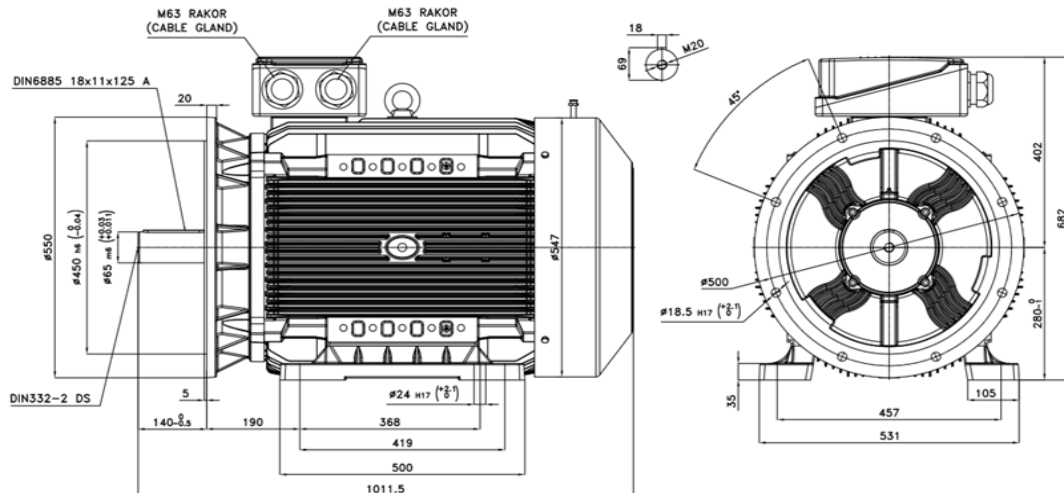



ELK MOTOR SAN. ve TİC. A.Ş.
www.elkmotor.com.tr
+90 (282) 726 92 94

TECHNICAL DATASHEET ACCORDING TO COMMISSION REGULATION (EU) 2019/1781 THREE PHASE INDUCTION MOTOR - SQUIRREL CAGE

Type : 4EG280S2C-PA-BA-000

Date : 01.01.2023

NAMEPLATE DATA

Power [kW]	: 75.0	Nominal Speed [rpm]	: 2982
Nominal Voltage [V]	: 400	Nominal Current [A]	: 124
Connection Type [Δ / Y]	: Δ	Nominal Moment [Nm]	: 240
Nominal Frequency [Hz]	: 50	Nominal Efficiency [η %]	: 95.6

THE POWER LOSSES AT SEVEN OPERATING POINTS ACCORDING TO COMMISSION REGULATION (EU) 2019/1781

Operating Point Number	Speed n/n_N [%]	Torque T/T_N [%]	Relative Power Losses P_L/P_N [%]	Efficiency η [%]
P ₁	90	100	4.5	95.3
P ₂	50	100	2.5	95.2
P ₃	25	100	1.8	93.5
P ₄	90	50	3.5	92.9
P ₅	50	50	1.7	93.6
P ₆	50	25	1.4	89.7
P ₇	25	25	0.7	90.1

MAP OF RELATIVE POWER LOSSES P_L/P_N [%]

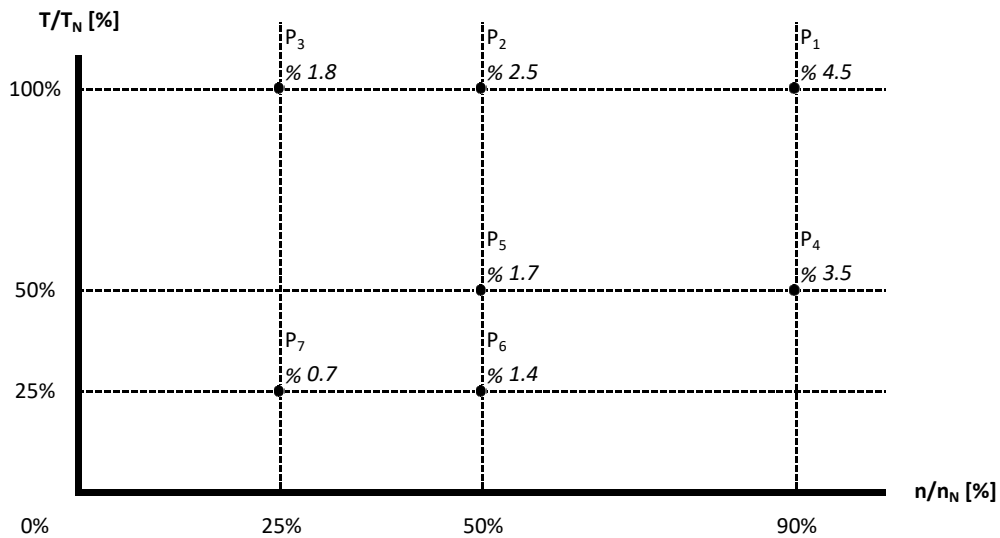

Manufactured and tested in accordance with IEC 60034

FR.AG.010 REV.NO: 04 REV.DATE: 01.01.2023

*Technical data are subject to change! There may be discrepancies between calculated and rating plate values.

*ELK Motor has right to change all the data without prior notice.

Motor Code : 4EG280S2C-PA-BA-000

Torque and Current Curves Related to Speed

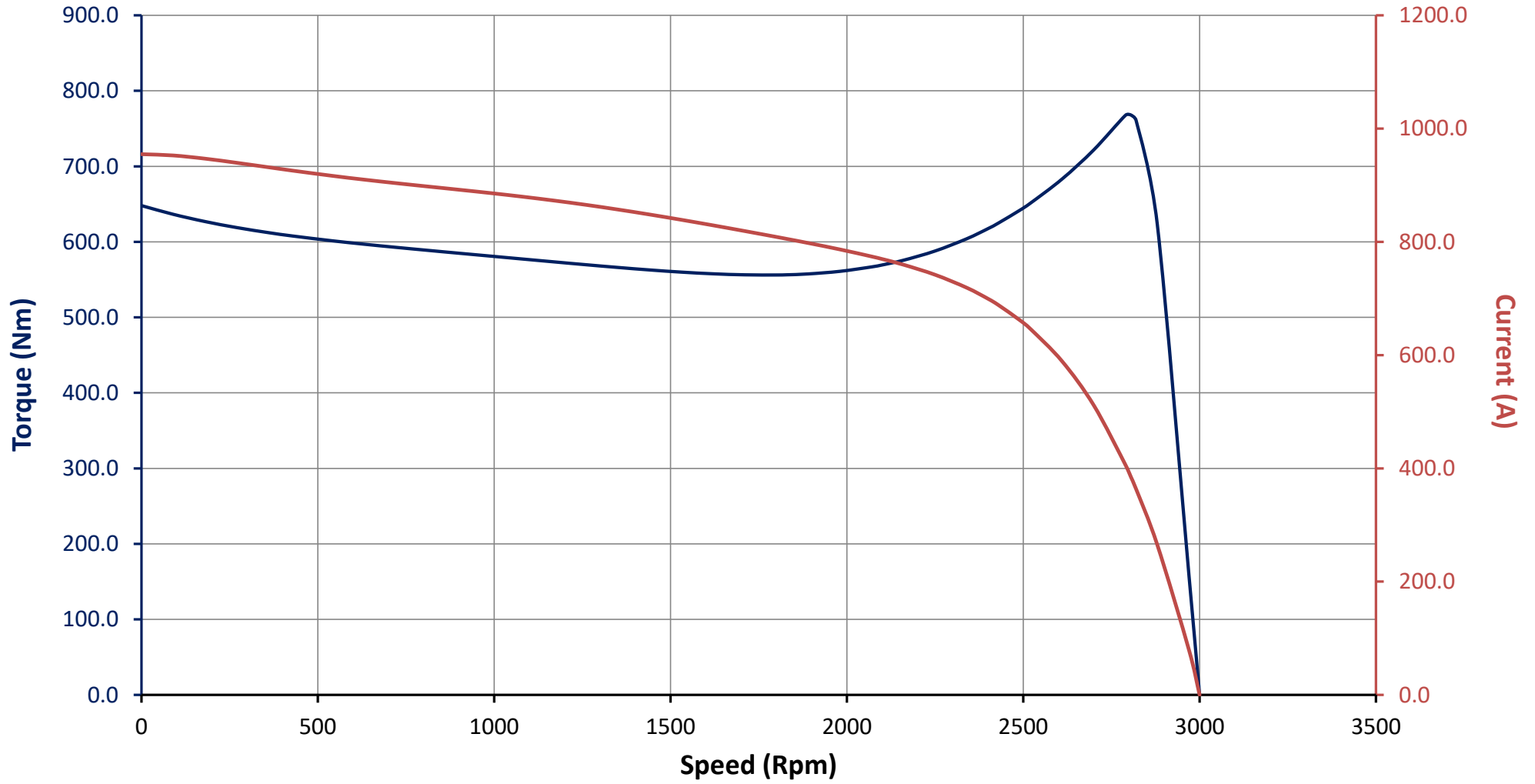

Motor Code : 4EG280S2C-PA-BA-000

Performance Curves Related to Rated Output

