

Type : 3EG225M4D-PD-BA-000

Date : 01.01.2023

Power [kW]	: 45.0	Efficiency Class	: IE3
Input Voltage [V]	: 400	Duty Cycle	: S1
Connection Type [Δ / Y]	: Δ	Service Factor	: 1.20
Frequency [Hz]	: 50	Frame Size	: 225M
Pole Number	: 4	Weight [kg]	: 350
Nominal Speed [rpm]	: 1477	Insulation Class	: F [155°C]
Nominal Current [A]	: 80.0	Temperature Rise	: B [80°K]
Nominal Moment [Nm]	: 291	Protection Class	: IP55
Nominal Efficiency [η]	: 94.2	Vibration Severity Grade	: A
Power Factor [$\cos\phi$]	: 0.86	Method of Cooling	: IC411 (TEFC)
Locked Rotor Current [I_a/I_n]	: 8.6	Direction of Rotation	: Bidirectional
Locked Rotor Torque [M_a/M_n]	: 3.3	Balance	: Half Key
Breakdown Torque [M_k/M_n]	: 3.2	Motor Thermal Protection	: PTC
Motor Color	: RAL 7031	Altitude Above Sea Level	: 1000m
Ambient Temperature	: -15°C / +40°C	Sound Pressure Level [dBA]	: 67

ELECTRICAL DATA

Δ / Y	U [V]	f [Hz]	P [kW]	n [rpm]	I [A]	η [%100]	η [%75]	η [%50]	Cos ϕ	Cl
Δ	400	50	45.0	1477	80.0	94.2	94.7	94.7	0.86	IE3
Y	690	50	45.0	1477	46.2	94.2	94.7	94.7	0.86	IE3
Δ	460	60	45.0	1782	69.3	95.0	95.0	94.2	0.86	IE3
Δ	460	60	52.2	1780	80.0	94.1	94.4	94.3	0.87	IE2

MECHANICAL DATA

Moment of Inertia [kgm ²]	: 0.44100
Bearing [DS / NS]	: 6313ZZ / 6213ZZ
Frame Material	: Cast Iron
Flange Type / Material	: B3 / Cast Iron
Cooling Fan Material	: Plastic
End Shield Material	: Cast Iron

TERMINAL BOX

Terminal Box Material	: Cast Iron
Terminal Box Position	: Top
Terminal Box Cable Entry	: 2xM50x1.5
Terminal Box Blind Cap	: --
Contact Screw Thread	: M8

MECHANICAL DIMENSIONS

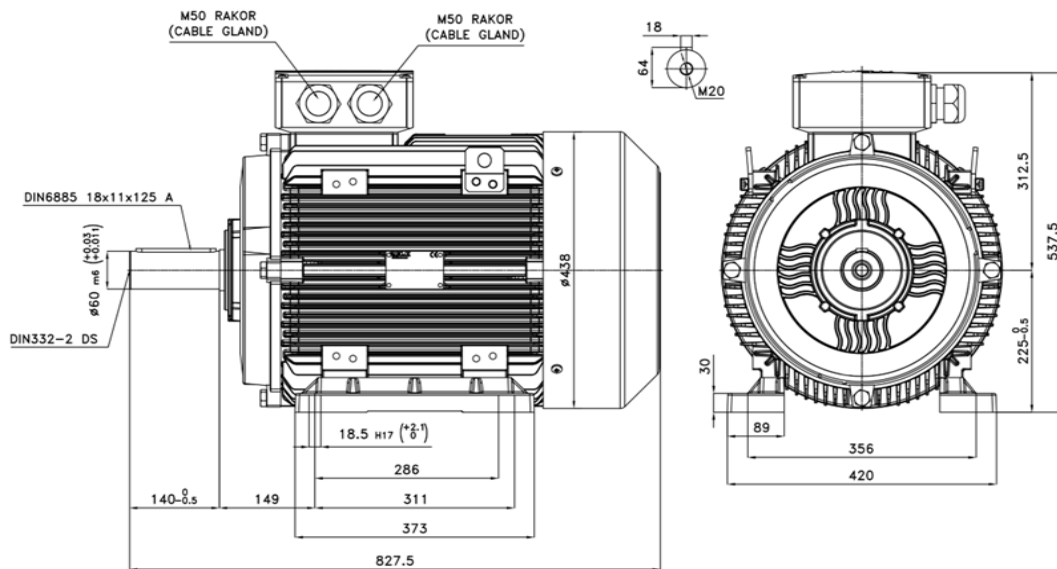



ELK MOTOR SAN. ve TİC. A.Ş.
www.elkmotor.com.tr
+90 (282) 726 92 94

TECHNICAL DATASHEET ACCORDING TO COMMISSION REGULATION (EU) 2019/1781 THREE PHASE INDUCTION MOTOR - SQUIRREL CAGE

Type : 3EG225M4D-PD-BA-000

Date : 01.01.2023

NAMEPLATE DATA

Power [kW]	: 45.0	Nominal Speed [rpm]	: 1477
Nominal Voltage [V]	: 400	Nominal Current [A]	: 80.0
Connection Type [Δ / Y]	: Δ	Nominal Moment [Nm]	: 291
Nominal Frequency [Hz]	: 50	Nominal Efficiency [η %]	: 94.2

THE POWER LOSSES AT SEVEN OPERATING POINTS ACCORDING TO COMMISSION REGULATION (EU) 2019/1781

Operating Point Number	Speed n/n_N [%]	Torque T/T_N [%]	Relative Power Losses P_L/P_N [%]	Efficiency η [%]
P ₁	90	100	6.0	93.8
P ₂	50	100	4.4	91.9
P ₃	25	100	3.8	86.7
P ₄	90	50	3.7	92.4
P ₅	50	50	2.1	92.2
P ₆	50	25	1.5	89.2
P ₇	25	25	0.8	88.1

MAP OF RELATIVE POWER LOSSES P_L/P_N [%]

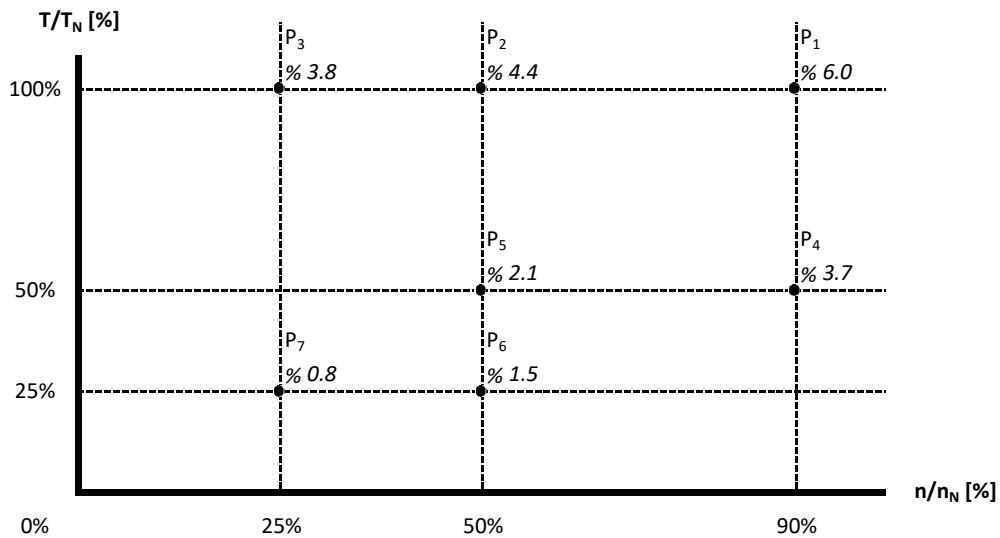

Manufactured and tested in accordance with IEC 60034

FR.AG.010 REV.NO: 04 REV.DATE: 01.01.2023

*Technical data are subject to change! There may be discrepancies between calculated and rating plate values.

*ELK Motor has right to change all the data without prior notice.

Motor Code : 3EG225M4D-PD-BA-000

Torque and Current Curves Related to Speed

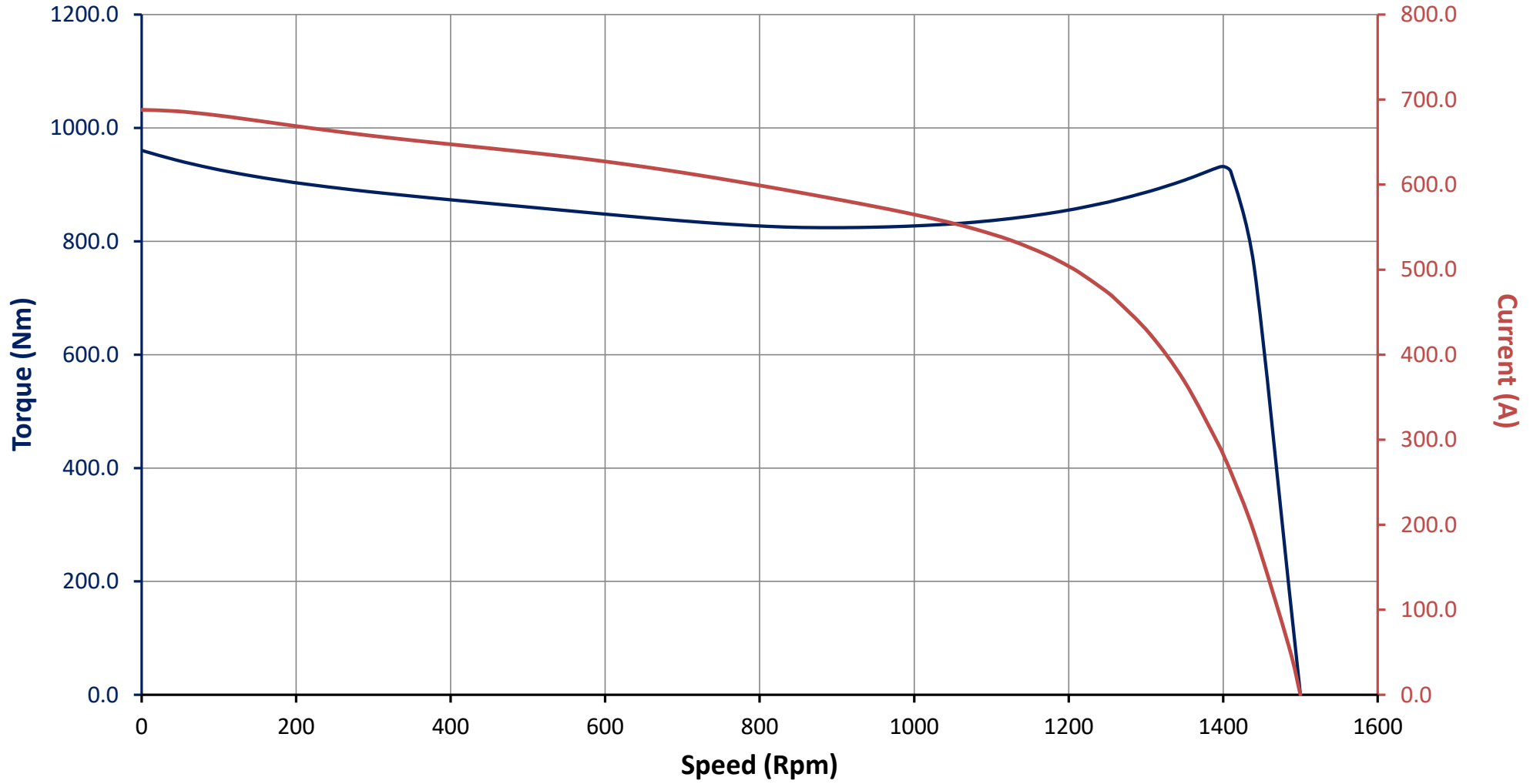

Motor Code : 3EG225M4D-PD-BA-000

Performance Curves Related to Rated Output

